

Nucleon-Nucleon Interactions from the Quark Model

la Universitat de Barcelona, 07 April 2010

Clark Downum (Barcelona)

Jirina Stone(Oxford/UTK),
Ted Barnes(ORNL/UTK), Eric Swanson(Pitt.), and
Isaac Vidaña (Coimbra)

Talk Outline

- Review NN Models and the Force
- The 3P0 Model of NNm Coupling Constants and Form Factors
- One Gluon Exchange
- Oxford Model of NN Force (Initial Results)
 - Phase Shifts
 - Deuteron
 - Nuclear Matter
 - Looking at the Potential
- Conclusions, Thoughts, etc.

What is the NN Force

- Nucleons are made of Quarks
- Quarks interact via Quantum Chromodynamics (QCD)
- QCD is confining
 - Nucleons are color singlets
 - QCD is non-perturbative
- NN (hadron-hadron) force is an artifact of QCD interactions between the quarks of the nucleons.
 - Colored van der Waals(?)

Understanding the NN Force, My Questions

- 1) What are the low-energy degrees of freedom of QCD between the nucleons?
- 2) Why are those d.o.f. *the* d.o.f. for QCD?
- 3) How are those d.o.f. driven by the microscopic quark/gluon dynamics?
- 4) Why is QCD expressed by those drivers?

Understanding the NN Force, My Questions

- 1) What are the low-energy degrees of freedom of QCD between the nucleons?
- 2) Why are those d.o.f. *the* d.o.f. for QCD?
- 3) How are those d.o.f. driven by the microscopic quark/gluon dynamics?
- 4) Why is QCD expressed by those drivers?

χ EFT is an answer to 1) and 2) (sort of)

CD-Bonn, Av18, Nijm-I don't attempt to answer these questions. They are (very good) quantitative parameterizations of the NN Force.

Understanding the NN Force, My Questions

- 1) What are the low-energy degrees of freedom of QCD between the nucleons?
- 2) Why are those d.o.f. *the* d.o.f. for QCD?
- 3) How are those d.o.f. driven by the microscopic quark/gluon dynamics?**
- 4) Why is QCD expressed by those drivers?

NN Models and Quarks/Gluons

- NN Models take little guidance from quark/gluon substructure of nucleons.
- These models work!
- QCD is non-perturbative \Rightarrow a proper derivation of NN forces is impossible.
- Constituent Quark Model often estimates strong physics
 - 3P0 Decay Model
 - Quark Cluster Model studies of One Gluon Exchange
- Can the Quark Model help us understand NN Dynamics?

Schematic Picture of NN Forces

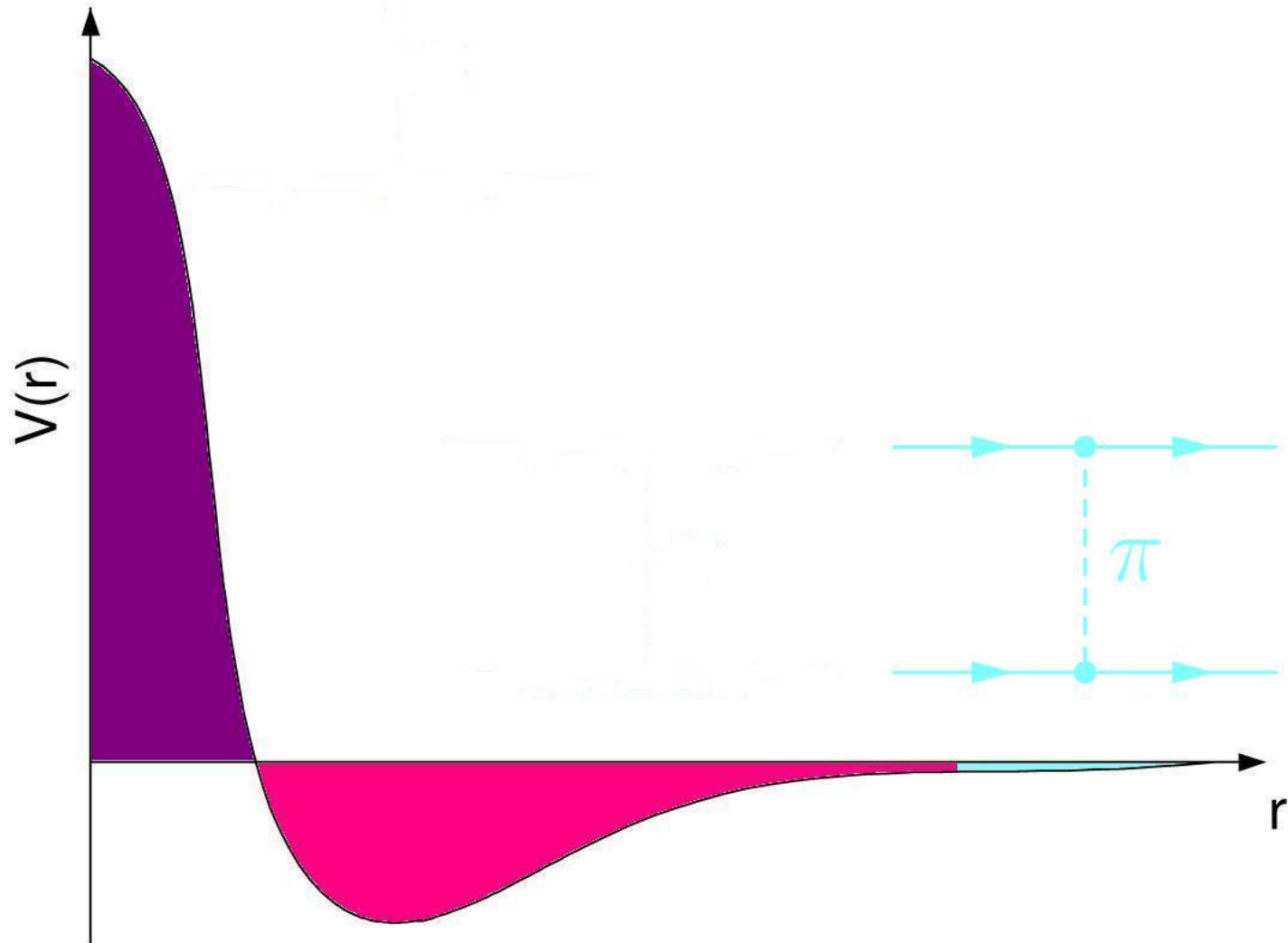

3P0 Model and Effective Strong 3-Point Vertices

$$H_{3P_0} = \gamma \sigma \cdot \vec{p} |q\bar{q}\rangle \langle 0|$$

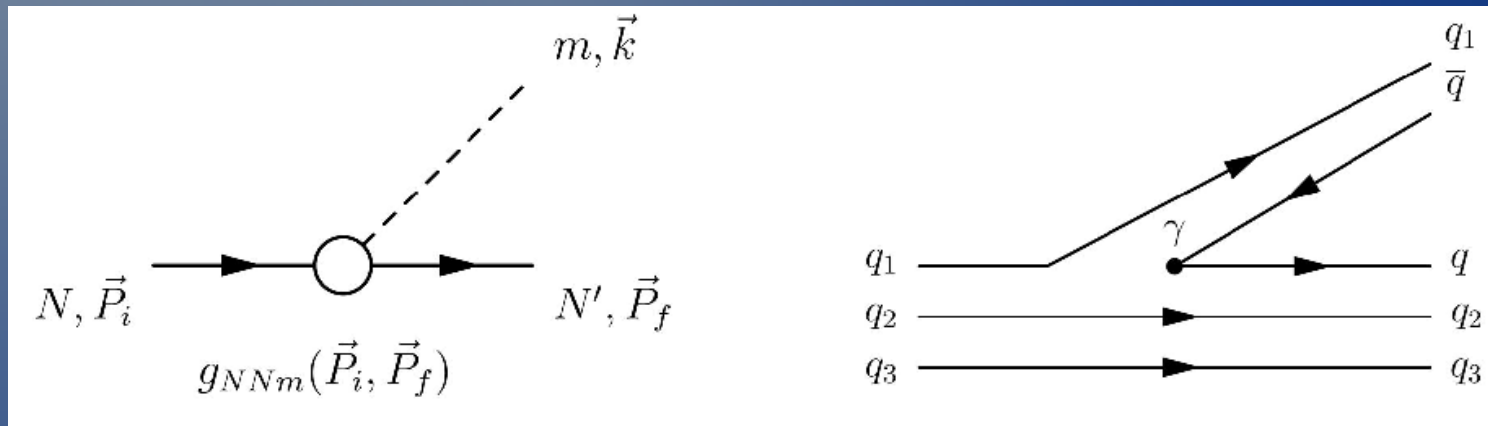

Equating the Two $\implies g_{NNm}(q^2) = \dots$

3P0 NNm Coupling Constants

$$g_{NN\pi} = \gamma 40 \sqrt{3} \pi^{3/4} m_N \sqrt{m_\pi} \frac{\beta^{3/2} (4\beta^2 + \alpha^2)}{(3\beta^2 + \alpha^2)^{5/2}}$$

$$g_{NN\sigma} = \gamma 108 \sqrt{2} \pi^{3/4} \frac{\alpha^4 \beta^{5/2} \sqrt{m_\sigma}}{(\alpha^2 + 3\beta^2)^{5/2}}$$

3P0 Coupling Constants and Form Factors

$$g_{NN\pi} = \gamma 40 \sqrt{3} \pi^{3/4} m_N \sqrt{m_\pi} \frac{\beta^{3/2} (4\beta^2 + \alpha^2)}{(3\beta^2 + \alpha^2)^{5/2}}$$

$$\mathcal{F}_S = \exp \left\{ -\frac{(\vec{P}_i + \vec{P}_f)^2}{24(3\beta^2 + \alpha^2)} - \frac{(\vec{P}_i - \vec{P}_f)^2}{6\alpha^2} \right\}$$

$$g_{NN\sigma} = \gamma 108 \sqrt{2} \pi^{3/4} \frac{\alpha^4 \beta^{5/2} \sqrt{m_\sigma}}{(\alpha^2 + 3\beta^2)^{5/2}}$$

$$\mathcal{F}_P = \left(1 + \frac{4\beta^2 + \alpha^2}{12\alpha^2(\alpha^2 + 3\beta^2)} (\vec{P}_f - \vec{P}_i)^2 \right) \exp \left\{ -\frac{(\vec{P}_i + \vec{P}_f)^2}{24(3\beta^2 + \alpha^2)} - \frac{(\vec{P}_i - \vec{P}_f)^2}{6\alpha^2} \right\}$$

Parameter Free Relations Among Coupling Constants

$$g_{\text{NN}\eta'} = \frac{3}{10\sqrt{2}} \left(\frac{m_{\eta'}}{m_{\pi}} \right)^{1/2} g_{\text{NN}\pi}$$

$$g_{\text{NN}\omega} = \frac{9}{10} \left(\frac{m_{\omega}}{m_{\pi}} \right)^{1/2} g_{\text{NN}\pi}$$

$$\kappa_{\omega} = -\frac{3}{2}$$

$$g_{\text{NN}\rho} = \frac{1}{6} \left(\frac{m_{\rho}}{m_{\omega}} \right)^{1/2} g_{\text{NN}\omega}$$

$$\kappa_{\rho} = +\frac{3}{2}$$

$$g_{\text{NN}a_0} = \frac{1}{3} \left(\frac{m_{a_0}}{m_{\sigma}} \right)^{1/2} g_{\text{NN}\sigma}$$

Numerical Values of Coupling Constants

Coupling	This Work	This Work	Paris	Nijmegen'93	CD-Bonn
$g_{NN\pi}$	14.2	[13.5]	[13.3]	13.3	[13.1]
$g_{NN\eta}$	6.0	5.7	–	9.8	–
$g_{NN\eta'}$	7.9	7.5	–	10.5	–
$g_{NN\sigma}$	5.0	N/A	–	17.9	(7.3; 14.9)
g_{NNa_0}	2.7	N/A	–	3.3	–
$g_{NN\omega}(\gamma_\mu)$	30.2	28.7	12.2	12.5	15.9
$g_{NN\rho}/g_{NN\omega}(\gamma_\mu)$	+0.33	+0.33	–	0.22	0.20
$\mathbf{K}_\omega(\boldsymbol{\sigma}_{\mu\nu}/\gamma_\mu)$	–3/2	–3/2	–0.12	0.66	0
$\mathbf{K}_\rho(\boldsymbol{\sigma}_{\mu\nu}/\gamma_\mu)$	+3/2	+3/2	–	6.6	6.1

Downum et al. Phys. Lett. B (638) 455-460
(2006). (With a π correction.)

CLAS Measurement!

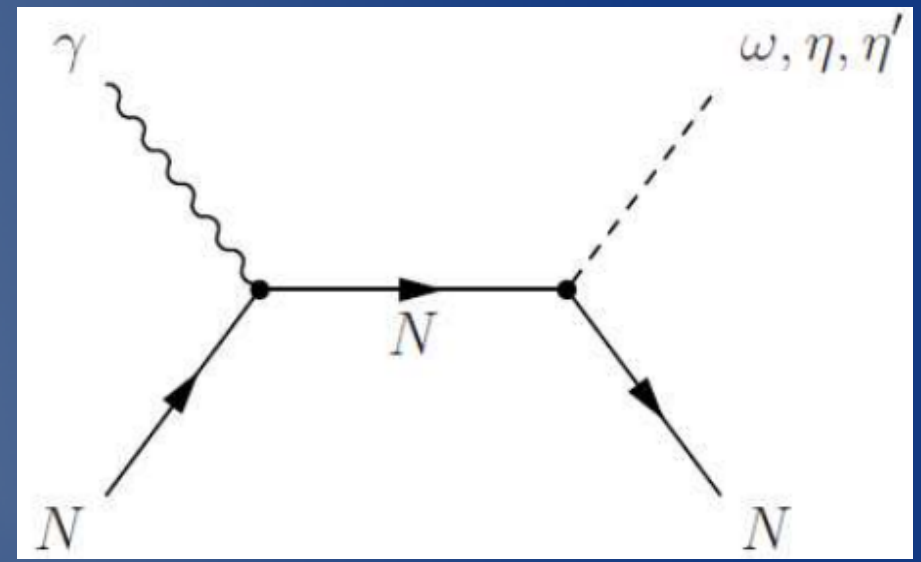
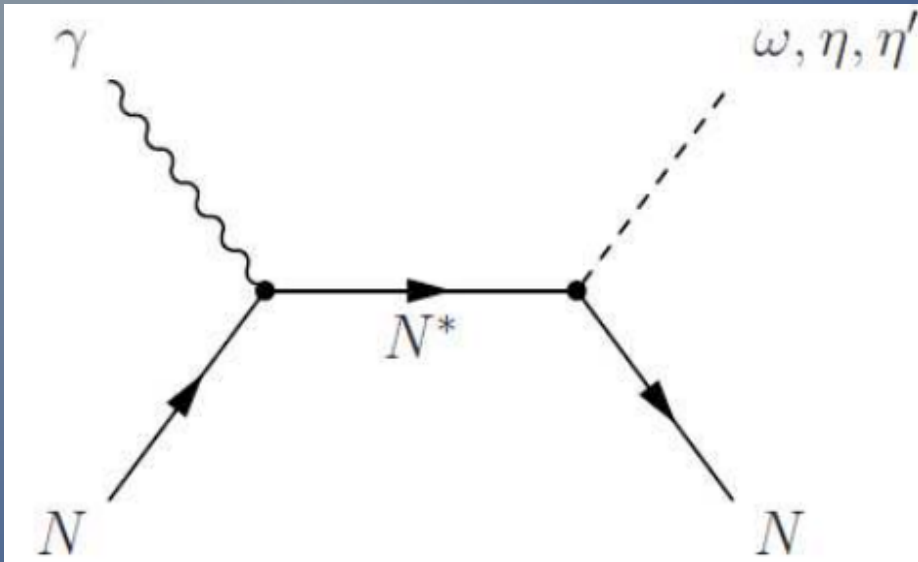

- Mike Williams reports (2007):

$$g_{NN\omega} = 1.04$$

$$\kappa_{\omega} = -2.10$$

- Which is significantly different than our values for the coupling constant, but not the ratio.

Back to NN Force Schematic

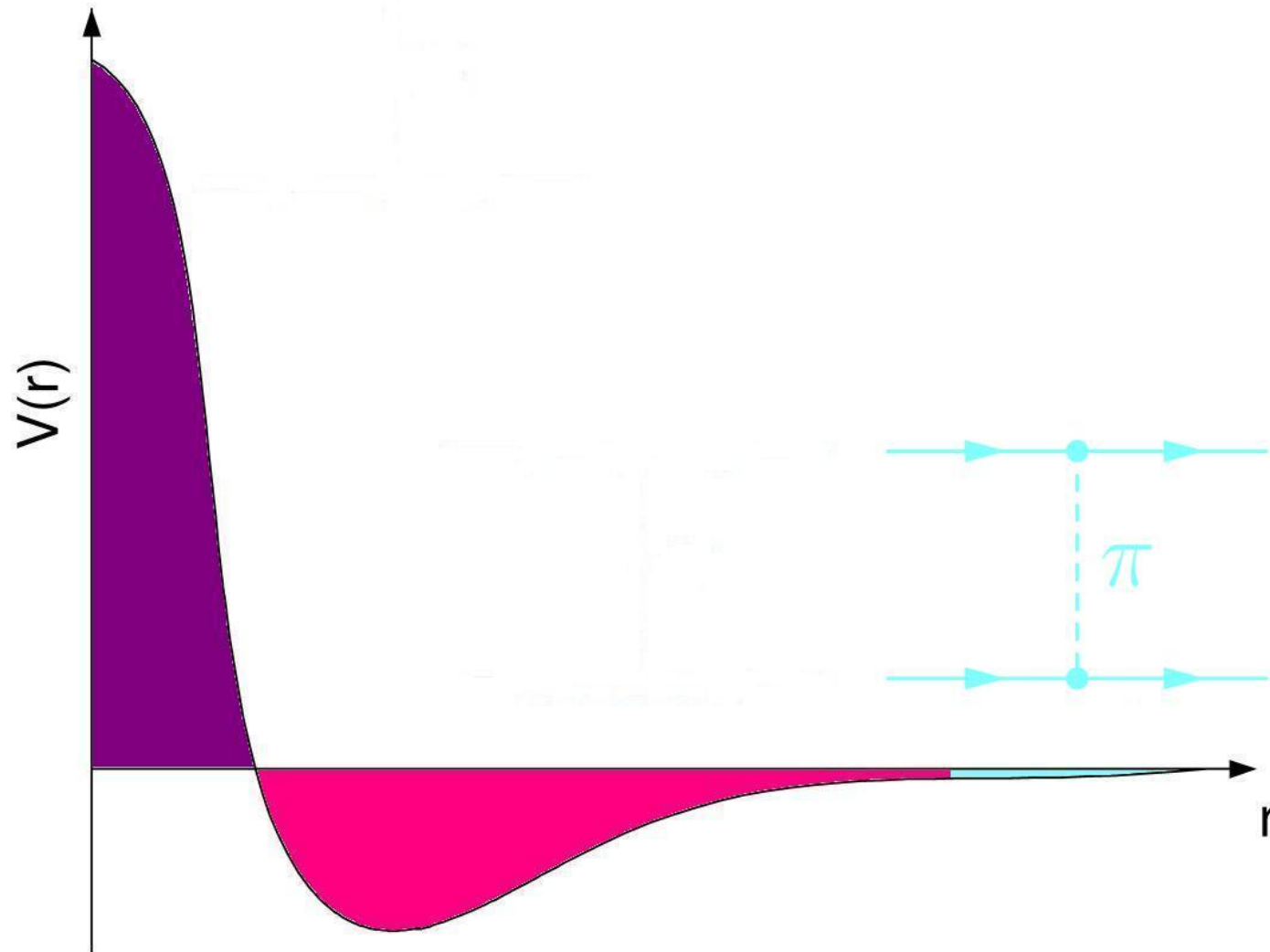

Quark Cluster Model Studies of One Gluon Exchange

- Date back to Liberman in 1977.
- Uses the Breit-Fermi Hamiltonian for perturbative QCD effects and a confining potential for non-perturbative QCD effects.
- Solve the Schrödinger Equation
- Extract a potential.
- They find: Tensor, Coulomb, Central and Spin-Orbit forces approximately cancel.
- Therefore, spin-spin contact interaction dominates.

Simple OGE Potential

Barnes et al. PRC 48 539(1993)

$$H_{\text{OGE Hyp}} = \sum_{i < j; i, j=1}^3 -\frac{8\pi\alpha_S}{3m_i m_j} \vec{s}_i \cdot \vec{s}_j \sum_{a=1}^8 \frac{\lambda_i^a}{2} \frac{\lambda_j^a}{2}$$

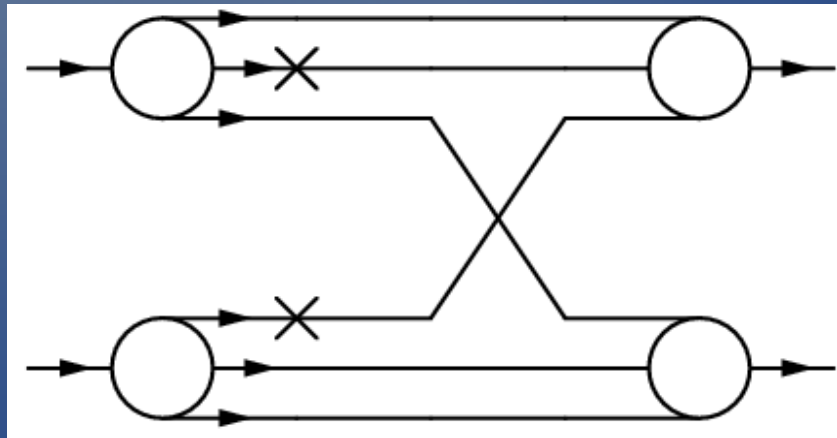

$$\mathcal{V}_{\text{OGE+CI}} = \frac{\alpha_S m}{3m_q^2} \sum_{n=1}^8 \omega_n \eta_n \exp \left\{ -A_n p_i^2 - C_n p_f^2 + B_n \vec{p}_i \cdot \vec{p}_f \right\}$$

Oxford Model

$$\mathcal{L}_{\text{Oxf}} = -ig_{\text{NN}\pi} \mathcal{F}_S \bar{\Psi} \gamma_5 \vec{\tau} \Psi \cdot \vec{\pi} - ig_{\text{NN}\sigma} \mathcal{F}_S \bar{\Psi} \Psi \sigma + i\mathcal{V}_{\text{OGE+CI}} [\bar{\Psi} \Psi \Psi \Psi]$$

- Wanted to try a simple model
- Introduced Charge Independence Breaking and Charge Symmetry Effects.
- χ PT says interactions are NN contact and π exchange
 - OPE
 - OGE + CI for contact
 - OSE for 2π Attraction
- See if we could fit the data...
 - Additional Repulsion Required (OOE)

T=0 Phase Shifts

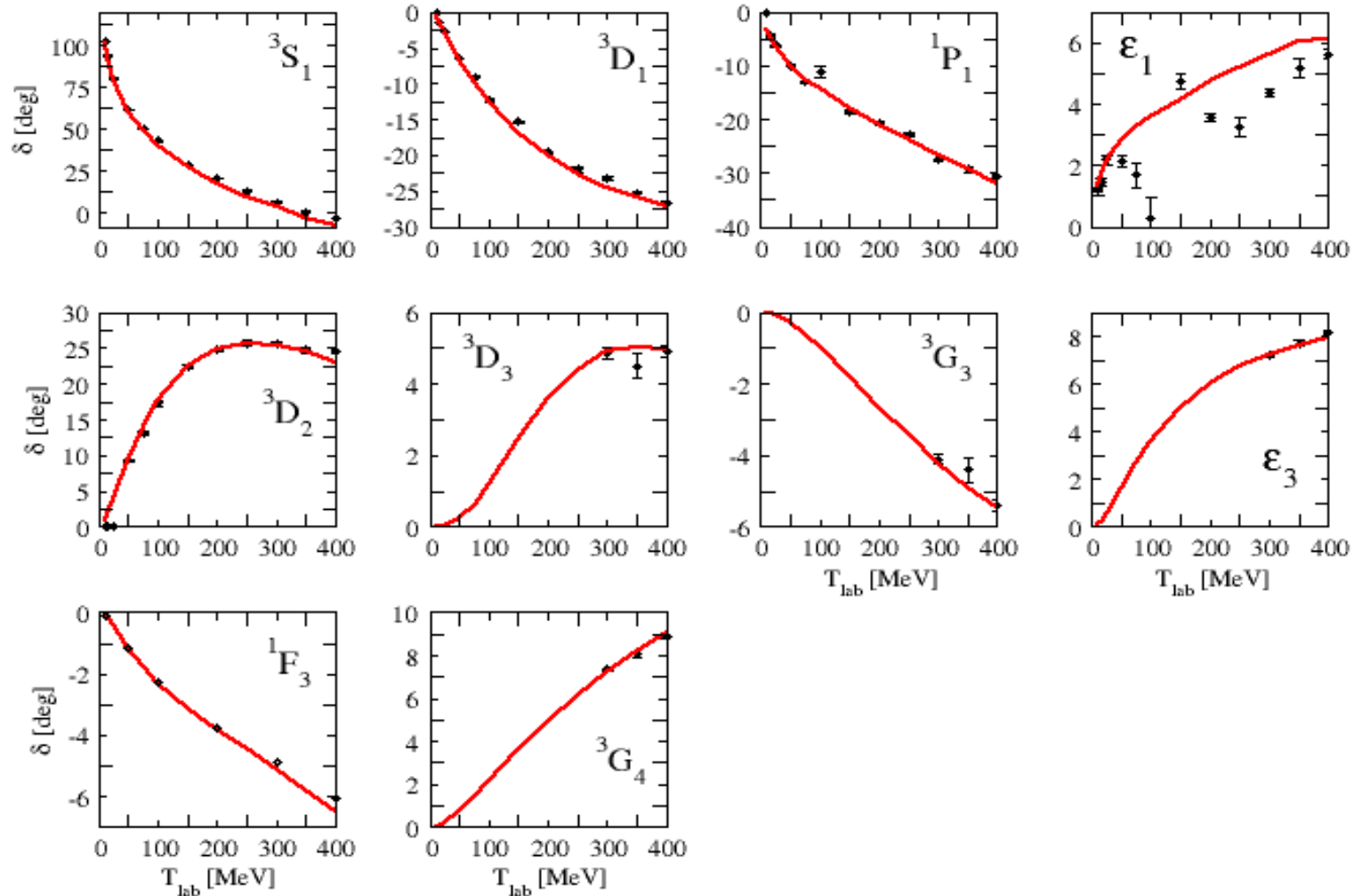

T=1 Phase Shifts

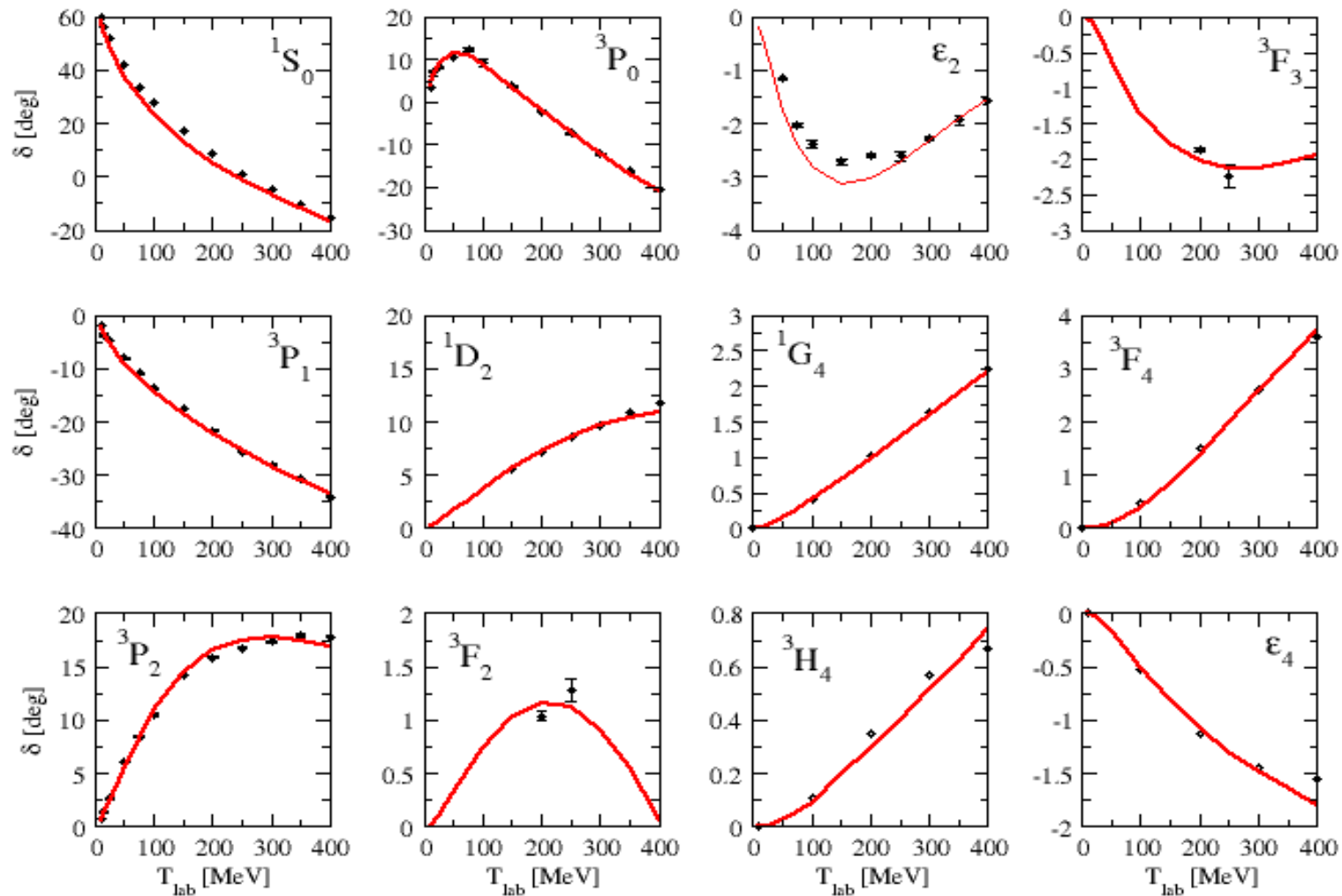

Scattering Lengths and Effective Ranges by Channel

	Oxford	CD-Bonn	Nijmegen I	Argonne v18	Experiment
	1S_0				
a_{pp}^C		-7.8154		-7.8064	-7.8149(29)
r_{pp}^C		2.773		2.788	2.769(14)
a_{pp}^N	-17.365	-17.4602		-17.164	
r_{pp}^N	2.886	2.845		2.865	
a_{nn}^N	-18.949	-18.9680		-18.818	-18.9(4)
r_{nn}^N	2.859	2.819		2.834	2.75(11)
a_{np}^N	-23.85	-23.7380		-23.084	-23.74(2)
r_{np}^N	2.753	2.671		2.703	2.77(5)
	3S_1				
a_t^N	5.46	5.4196	5.4194	5.402	5.419(7)
r_t^N	1.77	1.751	1.7536	1.752	1.753(8)

Deuteron Results

Property	Oxford	CD-Bonn	Nijmegen I	Argonne v18	Experiment
B_D [MeV]	2.224574	2.224575	2.224575	2.224575	2.224575(9)
A_S [fm ^{1/2}]	0.8913	0.8846	0.8841	.8850	0.8848(9)
η	0.0261	0.0256	0.0253	.0256	0.0256(4)
$\sqrt{\langle r^2 \rangle}$ [fm]	1.975	1.966	1.9666	1.967	1.971(6)
Q_d [fm ²]	0.2856	0.270	0.2719	.270	0.2859(3)
P_D [%]	5.56	4.85	5.664	5.76	

Nuclear Matter

Imagine a Volume V with A nucleons. We assume that the system has periodic boundary conditions and has translational invariance. The the limit as V and $A \rightarrow \infty$ but $\rho=A/V =$ constant of this matter is called Nuclear Matter.

Two variables:

- Density (ρ)
- Proton Fraction: x_p

$x_p = 1/2$ is Symmetric Nuclear Matter (SNM)

$x_p = 0$ is Pure Neutron Matter (PNM)

$x_p = \text{else}$ is Asymmetric Nuclear Matter (ANM)

We are interested in E/A , the Equation of State (EOS).

Properties of Nuclear Matter from Heavy Nuclei

$$\frac{E}{A} = a_1 + a_2 A^{-\frac{1}{3}} + a_3 x_p^2 A^{-\frac{10}{3}} + a_4 (1 - 2x_p)^2 + a_5 A^{-\frac{7}{4}}$$

$$\lim_{A \rightarrow \infty} \frac{E}{A} \Big|_{x_p = \frac{1}{2}} = a_1 \approx -16.1 \text{ MeV}$$

$$\lim_{A \rightarrow \infty} \frac{\partial^2 E}{\partial x_p^2} \frac{1}{A} = 8a_4 \Rightarrow \frac{1}{8} \lim_{A \rightarrow \infty} \frac{\partial^2 E}{\partial x_p^2} = a_4 \approx 23 \text{ MeV}$$

$$\lim_{A \rightarrow \infty} \frac{\partial^2 E}{\partial x_p^2} \frac{1}{A} \approx \lim_{A \rightarrow \infty} \frac{E}{A} \Big|_{x_p = \frac{1}{2}} - \lim_{A \rightarrow \infty} \frac{E}{A} \Big|_{x_p = 0}$$

Qualitative EOS for SNM

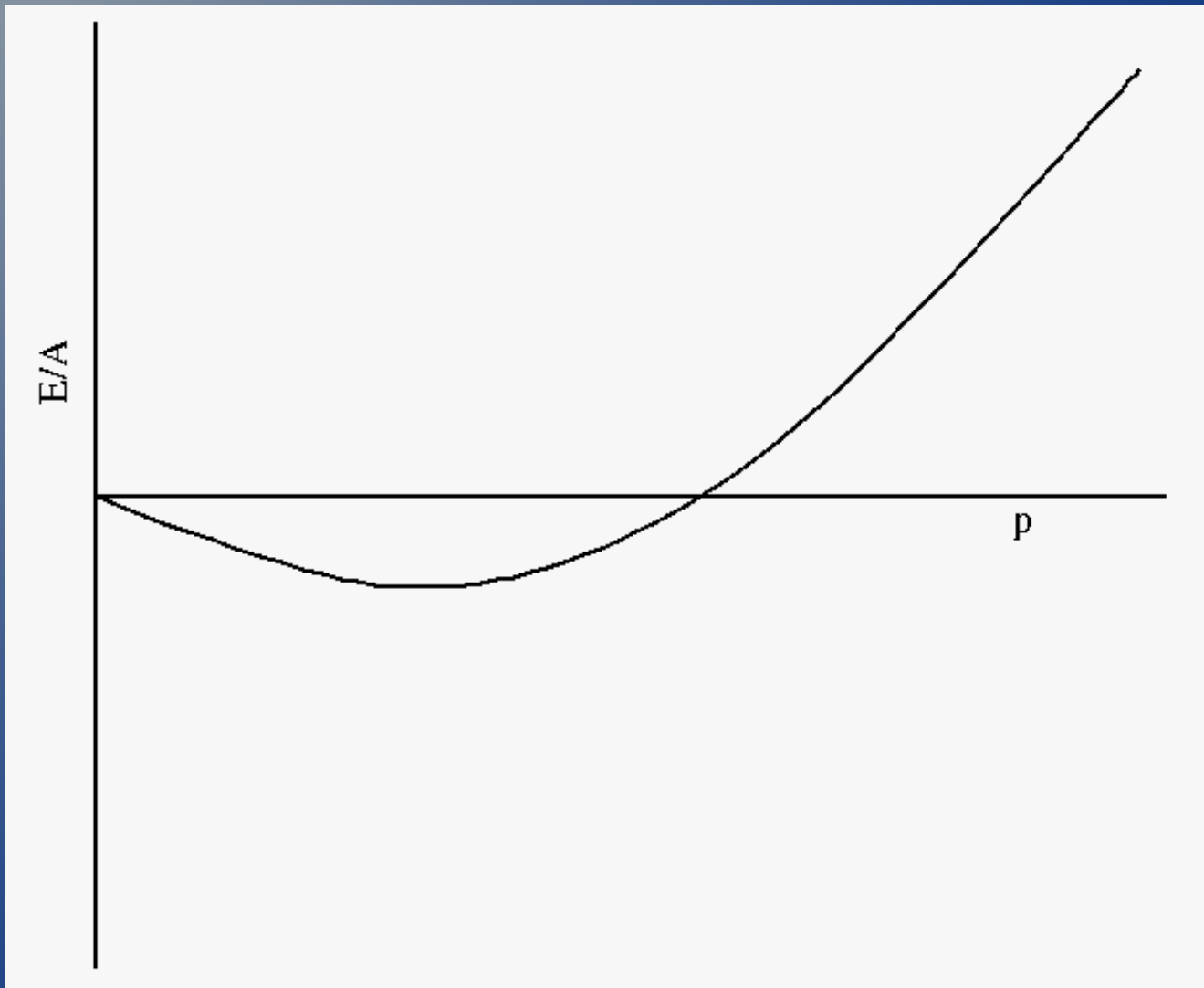

Change of EOS from SNM to PNM

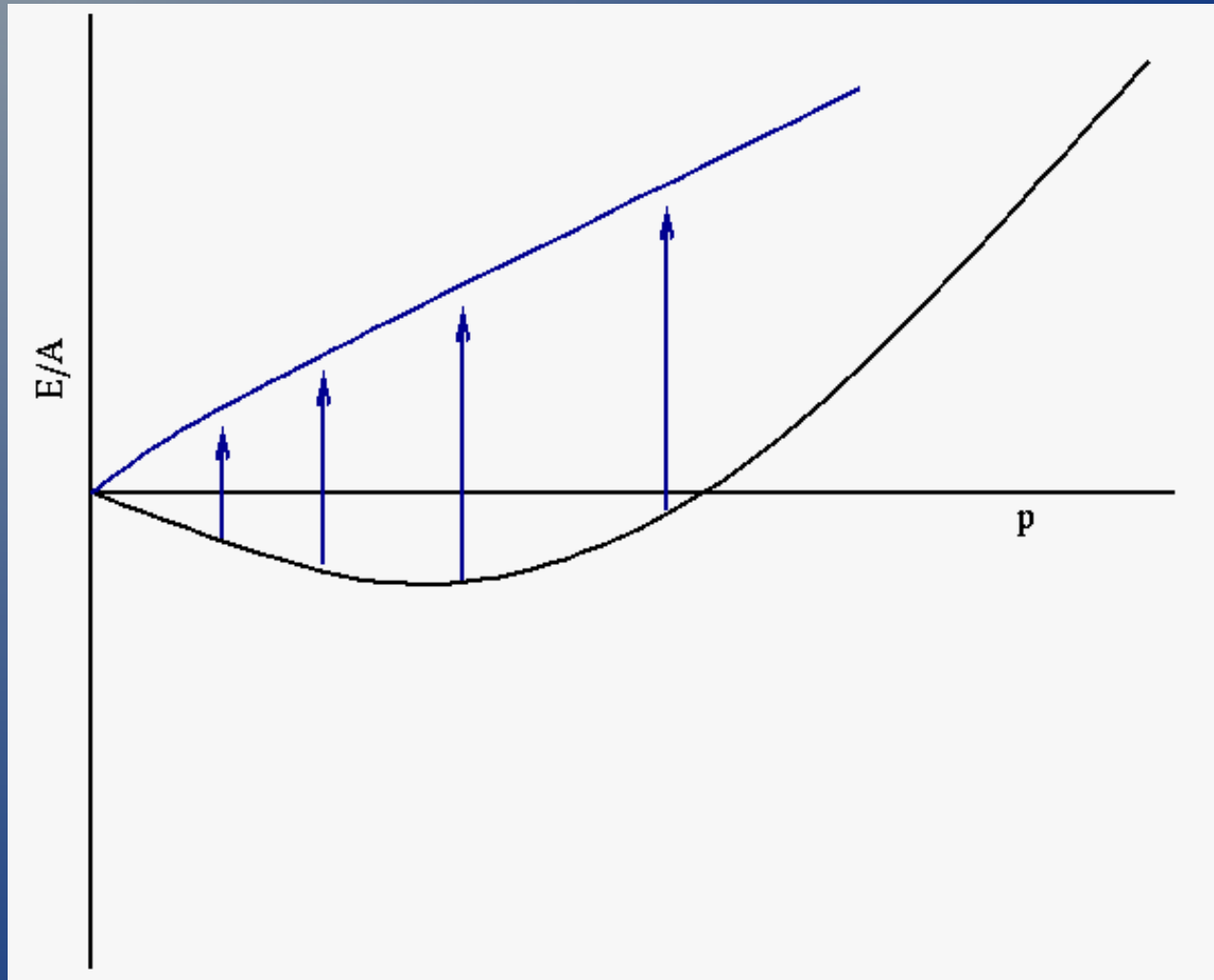

Calculating the EOS

$$H\psi = (T + V)\psi = E\psi$$

- Need to solve the many body Schrödinger equation.
- Non-trivial but technical.
- First person to try perturbation theory techniques to nuclear matter: Brueckner. Hence the Brueckner Hartree Fock formalism.

Formalism and Interaction Matter!

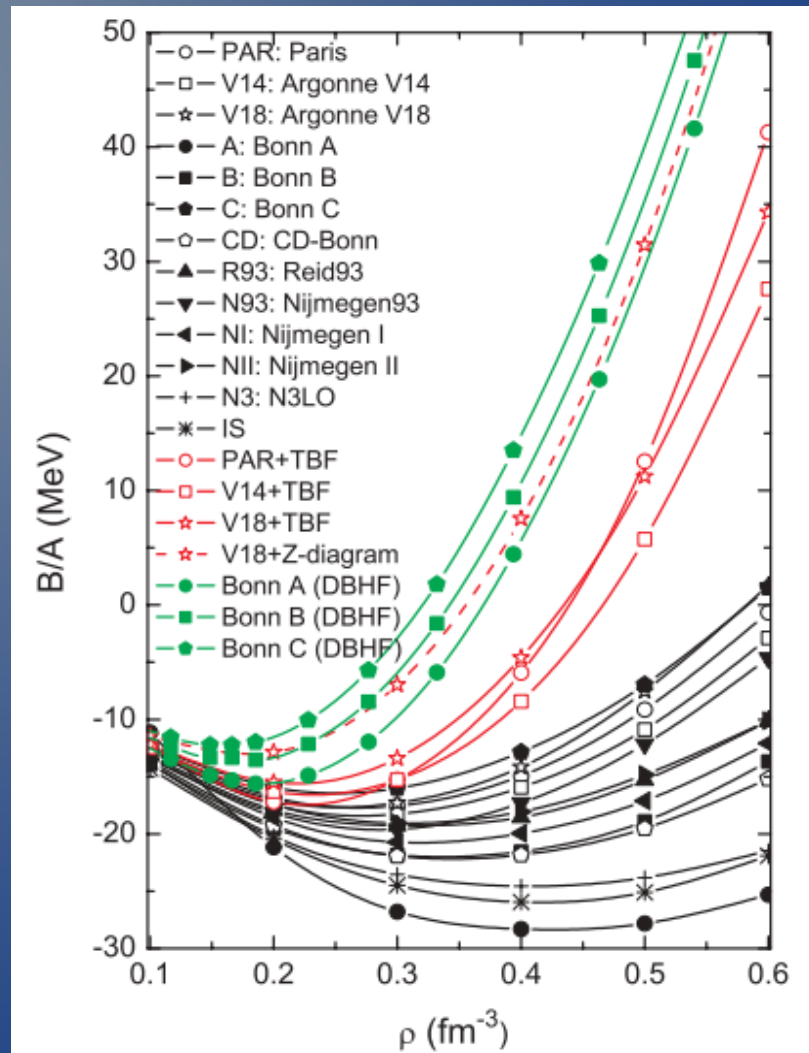

PHYSICAL REVIEW C **74**, 047304 (2006)

Nuclear matter saturation point and symmetry energy with modern nucleon-nucleon potentials

Z. H. Li,¹ U. Lombardo,² H.-J. Schulze,³ W. Zuo,⁴ L. W. Chen,¹ and H. R. Ma¹

EOS Results

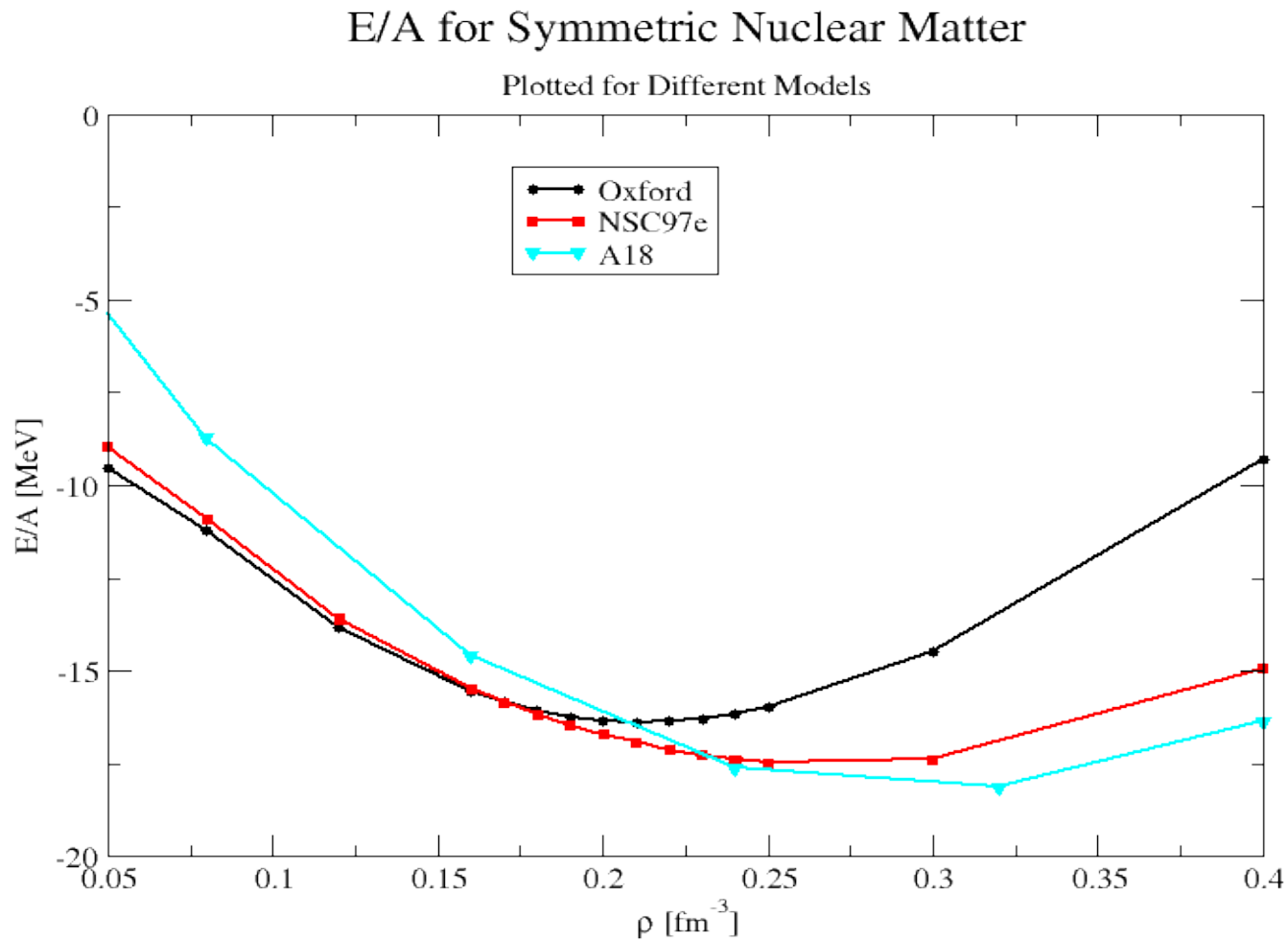

EOS Results (Cont'd.)

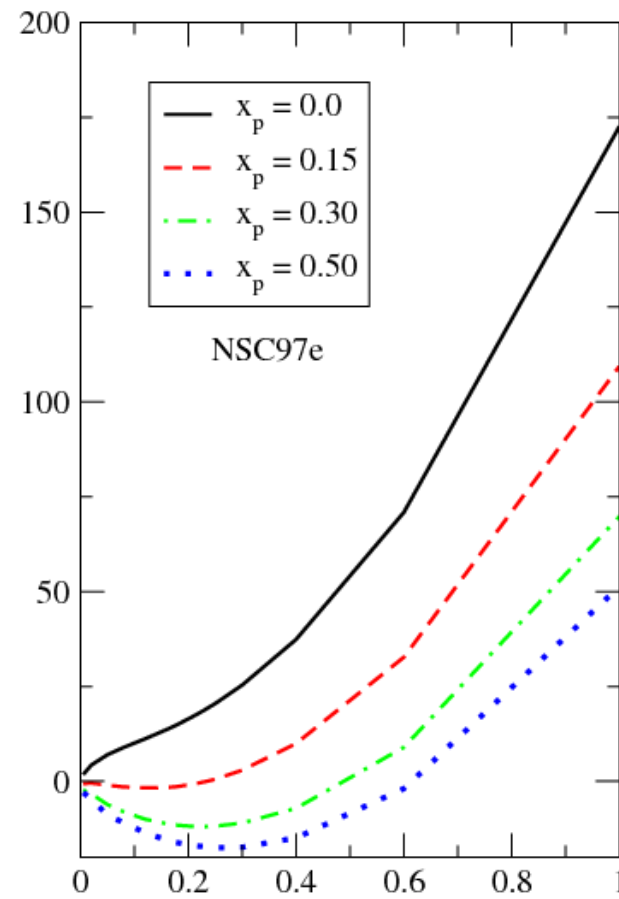
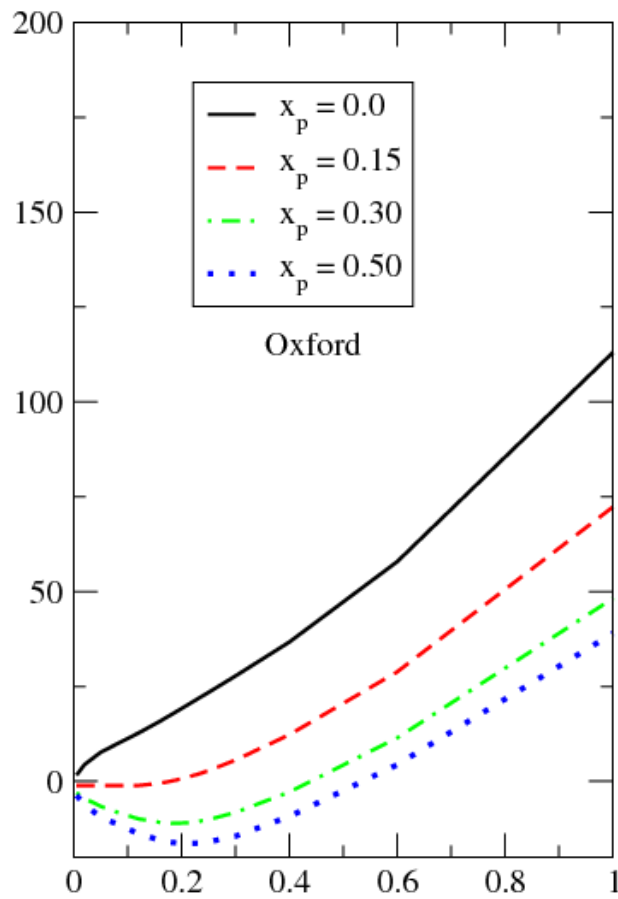

Symmetry Energy

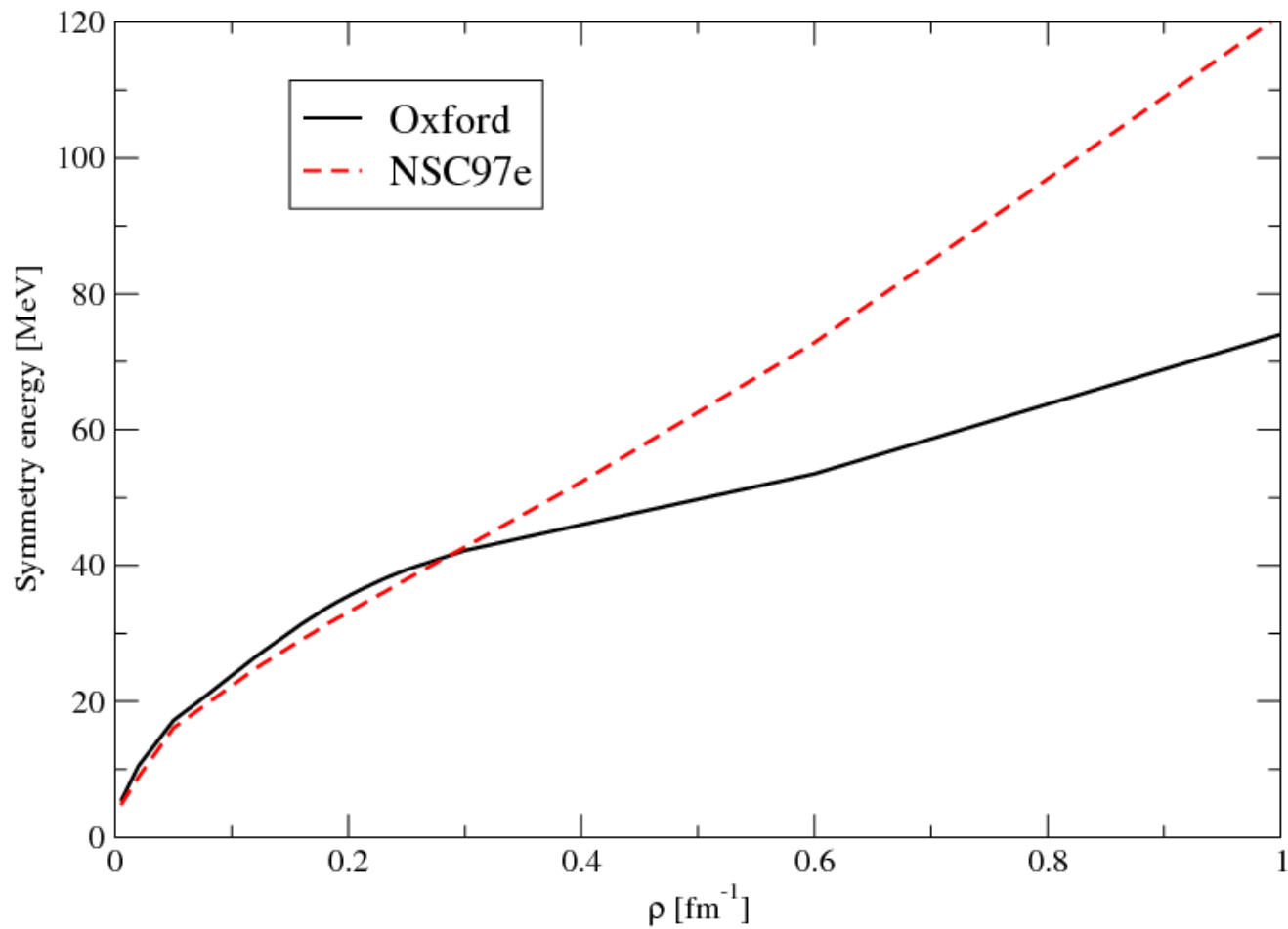

Comparison of EOS Results

Property	Oxf.	CD-Bonn	Nijm I	Av18	Expt.
$\rho_0[\text{fm}^{-3}]$	0.25	0.374	0.348	0.259	0.16
$E/A[\text{MeV}]$	-16.02	-21.9	-20.7	-17.3	\approx -16
$E_{\text{sym}}[\text{MeV}]$	38.0	31.1	30.5	29.9	

Oxford and Nijmegen Potential by Partial Wave

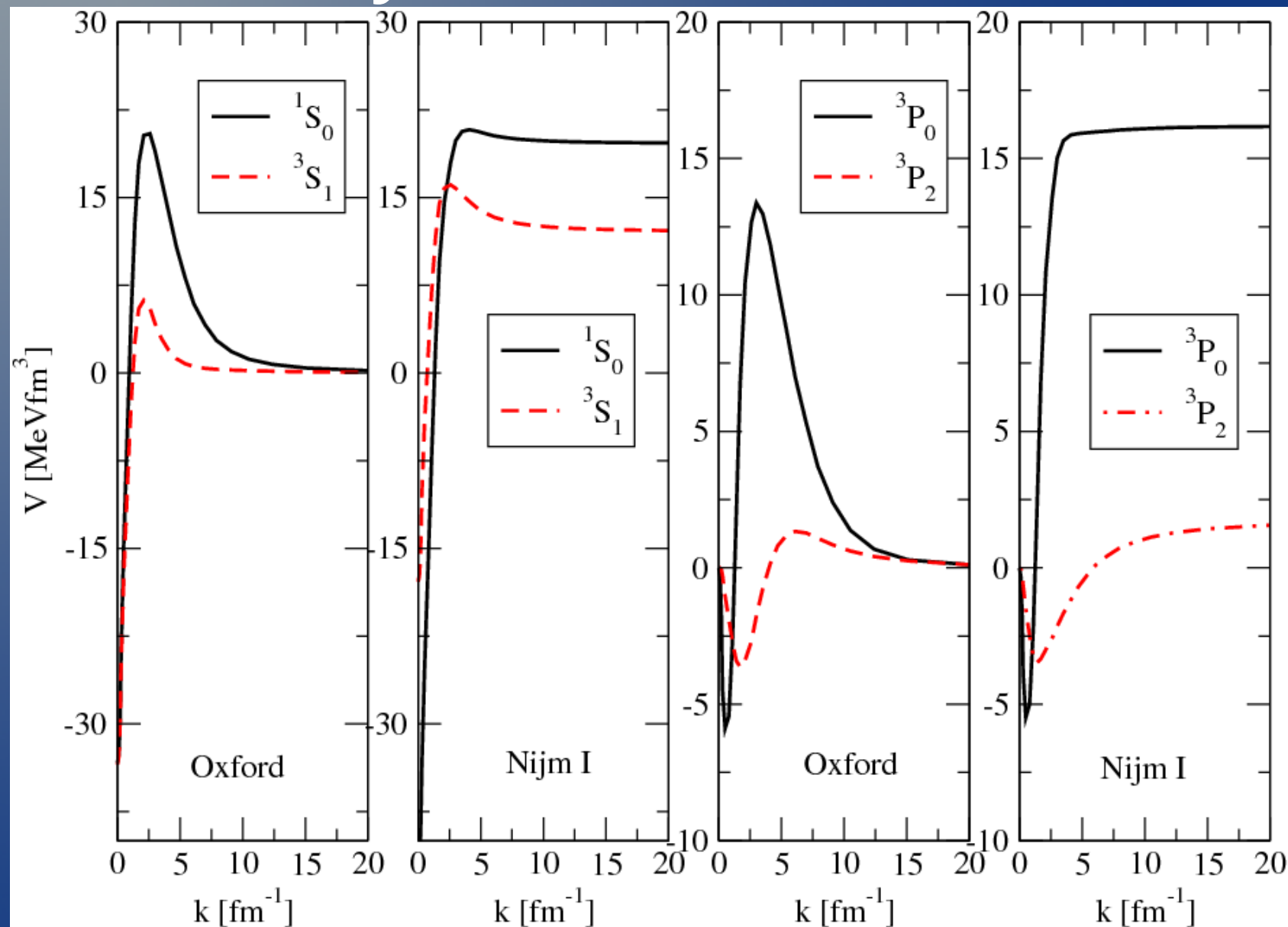

Oxford and Nijmegen Potential by Partial Wave (Cont'd.)

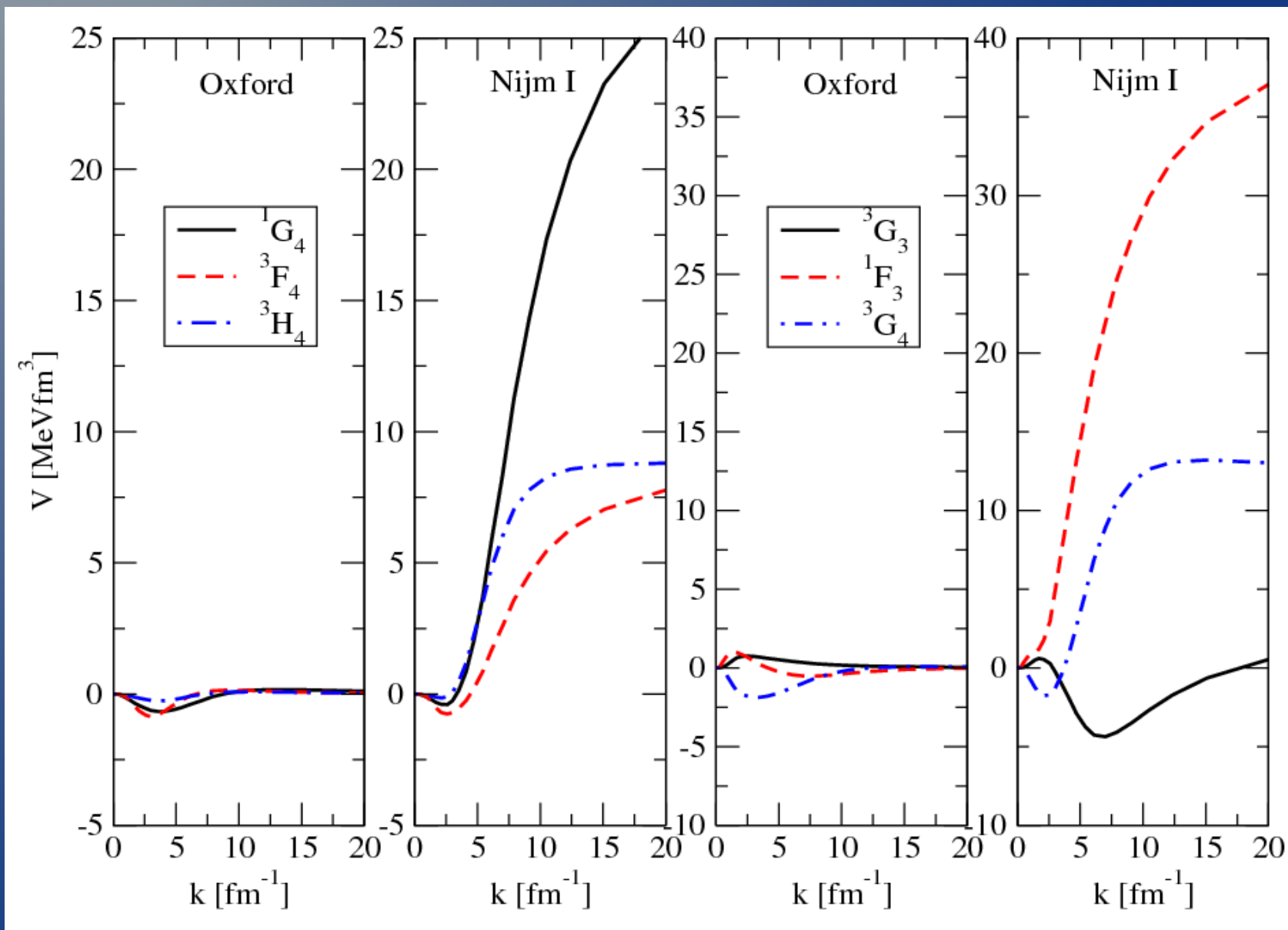

What I'm Doing – Parameters

Force Component	Parameters			
OGE+CI (Core)	α_S	α_{Core}	m_q	
OPE (π)	$g_{\text{NN}\pi}$	α_π	β_π	
OSE (σ)	$g_{\text{NN}\sigma}$	α_σ	β_σ	m_σ
OOE (ω)	$g_{\text{NN}\omega}$	α_ω	β_ω	

What I'm Doing – Parameters

Force Component	Parameters			
OGE+CI (Core)	$\alpha_S = 1.0$	$\alpha_{\text{Core}} = 0.7 \text{ GeV}$	$m_q = .33 \text{ GeV}$	
OPE (π)	$g_{\text{NN}\pi} = 13.0$	$\alpha_\pi = 0.4 \text{ GeV}$	$\beta_\pi = 0.6 \text{ GeV}$	
OSE (σ)	$g_{\text{NN}\sigma} = 6.0$	$\alpha_\sigma = 0.5 \text{ GeV}$	$\beta_\sigma = 0.5 \text{ GeV}$	$m_\sigma = *** \text{ GeV}$
OOE (ω)	$g_{\text{NN}\omega} = ***$	$\alpha_\omega = 0.4 \text{ GeV}$	$\beta_\omega = 0.4 \text{ GeV}$	

- Literature Values:
 - $\alpha_s = 0.6 - 1.4$
 - $\alpha = 0.25-0.4 \text{ GeV}$
 - $\beta = 0.3-0.4 \text{ GeV}$
 - $g_{\text{NN}\pi} \approx 13.0$
 - $m_q = 0.3-0.4 \text{ GeV}$

Partial Wave Parameters

Partial Wave Channel	$m_\sigma(\text{GeV})$	$g_{NN\omega}$
1S_0	0.407	0.0
3P_0	0.450	12.0
1P_1	0.540	14.0
3P_1	0.490	10.5
3S_1	0.501482	0.0
3D_1	0.431	0.0
ε_1	0.501482	0.0
1D_2	0.455	0.0
3D_2	0.620	0.0
3P_2	0.635	0.0
3F_2	0.440	12.5
ε_2	0.440	12.5
1F_3	0.600	14.0
3F_3	0.455	0.0
3D_3	0.520	0.0
3G_3	0.520	0.0
ε_3	0.520	0.0
1G_4	0.440	0.0
3G_4	0.650	0.0
3F_4	0.520	0.0
3H_4	0.520	0.0
ε_4	0.520	0.0

Thoughts, Conclusions, etc.

- The most significant failure of the model is the necessity of including an ad-hoc ω exchange in some P-waves.
- The range of parameter variation by partial wave, while not extreme, is disappointing.
- We can alter the physics of the model self-consistently to explore other mechanisms (2π exchange, etc.)

Thoughts, Conclusions, etc. (Cont'd.)

- The ability of the simple and constrained model to well reproduce so many observables connected to the NN interaction is surprising and encouraging.
- The model raises important physics issues:
 - Non-locality
 - ρ exchange
 - High momentum behavior, etc.
- Work continues.

End of Talk

Thank you for your attention!

Questions?

Feedback?